

Significant reduction in labor hours
Easy cable system

IAI
Quality and Innovation

An industry first!

e-Wiring System

What is the e-Wiring System?

Run the bus cable and branch off the branch cables as needed to connect to the actuators.

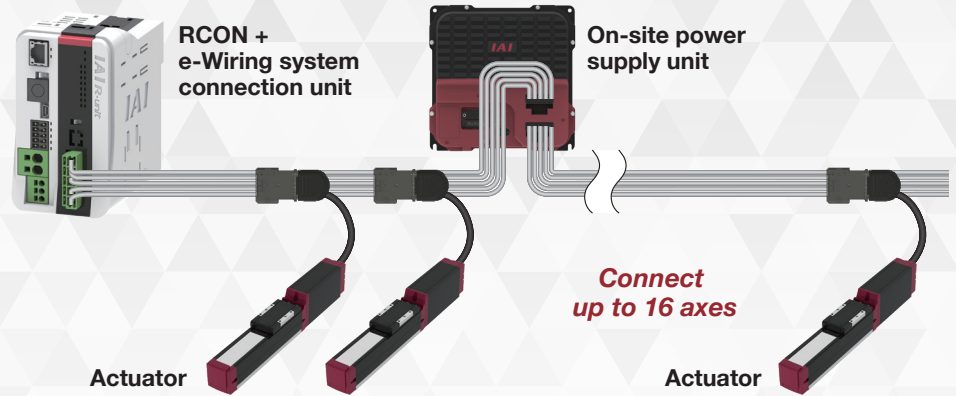

Application example

ELECYLINDER transfer unit with 12 axes

This unit clamps workpieces at the tip of the ELECYLINDER's cartesian axis

Conventional wiring

Space for the cable carriers installation is needed

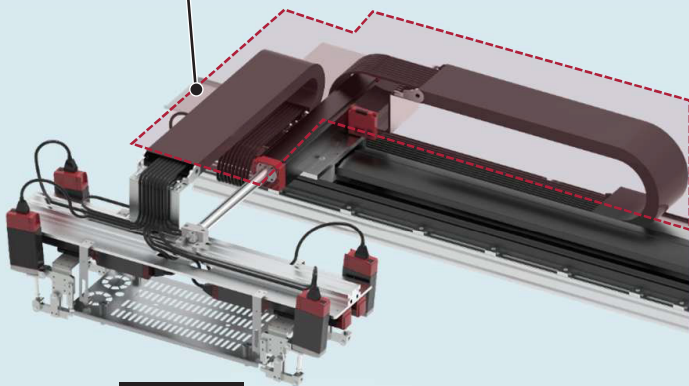

BEFORE

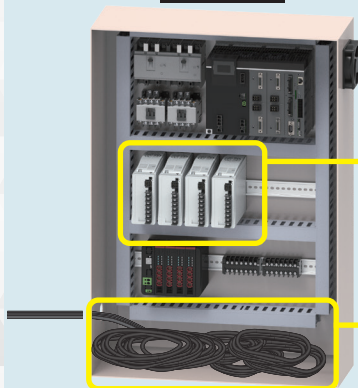

Power unit installation space is necessary inside the controller

The excess cables are coiled up

e-Wiring System

POINT

No cable carriers needed!

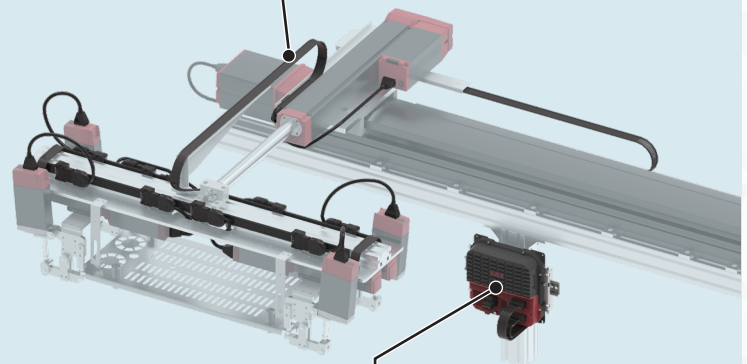

POINT

On-site power supply unit

AFTER

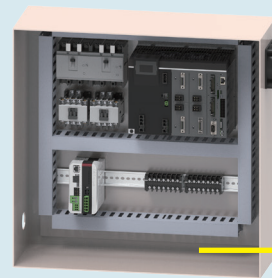

Installing a 24V power supply within the work site helps save space in the control panel.
(Our PSA-24 can be installed in parallel with the on-site power supply unit)

No unnecessary cables!

Reduces labor hours at each stage from design to maintenance

Design

BEFORE

Requires selecting cable length for each actuator

AFTER

No need to select cable length



Reduces Design Time

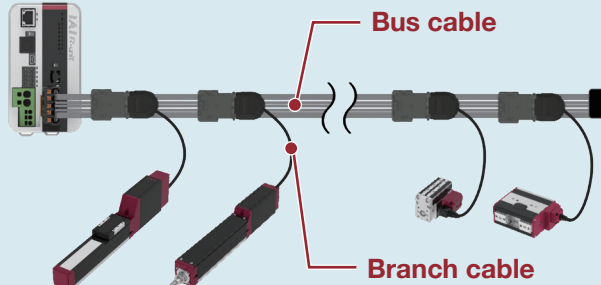

Run the bus cable on the equipment and branch off the branch cables using dedicated connectors.

Assembling

BEFORE

Wiring work takes time because there are many cables

AFTER

Cable installation labor hours



Approx.

64% Reduced

Labor time of conventional wiring work
(Our actual measurement result)

124 minutes

Wiring labor time for the e-Wiring System



45 minutes

Maintenance

BEFORE

Multiple types of cable lengths are necessary for maintenance of each actuator

AFTER

Maintenance cables are significantly reduced to just two types



In addition!

- ✓ No need to purchase excessively longer cables, **saving resources!**
- ✓ Only the exact amount of cables are purchased, **reducing costs!**
- ✓ **Lower cost** due to shorter total cable length!



Can be cut to the required lengths

Instruction manual available!

Refer to the instruction manual for detailed connection instructions.
intelligentactuator.com/e-wiring-manual



Manual



← The product catalog is coming soon!

IAI America, Inc.

USA Headquarters & Western Region (Los Angeles): 2690 W. 237th Street, Torrance, CA 90505 (310) 891-6015
Midwest Branch Office (Chicago): 110 East State Parkway, Schaumburg, IL 60173 (847) 908-1400
Southeast Branch Office (Atlanta): 1220 Kennestone Circle, Suite 108, Marietta, GA 30066 (678) 354-9470

www.intelligentactuator.com

IAI Group Headquarters and Main Factory:
1210 Iharacho, Shimizu-ku, Shizuoka-shi, Shizuoka, 424-0114, JAPAN

The information contained in this product brochure may change without prior notice due to product improvements.

IAI Industrieroboter GmbH

Ober der Röh 4,
D-65824 Schwalbach am Taunus, Germany

IAI Robot (Thailand) Co., Ltd.

825 Phairojkijja Tower 7th Floor, Debaratana Rd.,
Bangna Nuea, Bangna, Bangkok 10260, Thailand

IAI (Shanghai) Co., Ltd.

SHANGHAI JIAHUA BUSINESS CENTER A8-303,
808 Hongqiao Rd. Shanghai 200030, China

1.3.5 Characteristics of On-Site Power Supply Unit

- Input Power Source and Output Power Source

It is applicable for wide input from 100 to 230V AC for the input voltage. The output power supply is rated at 300W continuous and the peak instantaneous power of 600W.

Also, as it is equipped with PFC, it is applicable for the Harmonic Regulations.

- Capable of Monitoring Operation

Each type of status data (e.g. output voltage, output current, peak current, load ratio, etc.) can be monitored on a PC tool.

The status data can be also monitored on the RCON gateway unit via the field network.

- Parallel Connection

In order to drive several motors, parallel operation of four units at the maximum is available.

Refer to [Chapter 4 Wiring].

* It is also available to make a parallel operation with PSA-24.

- Cable Saving

When constructing a system with e-Wiring System, there should only be two cables, “AC cable” and “flat cable”, needed for wiring from a control panel.

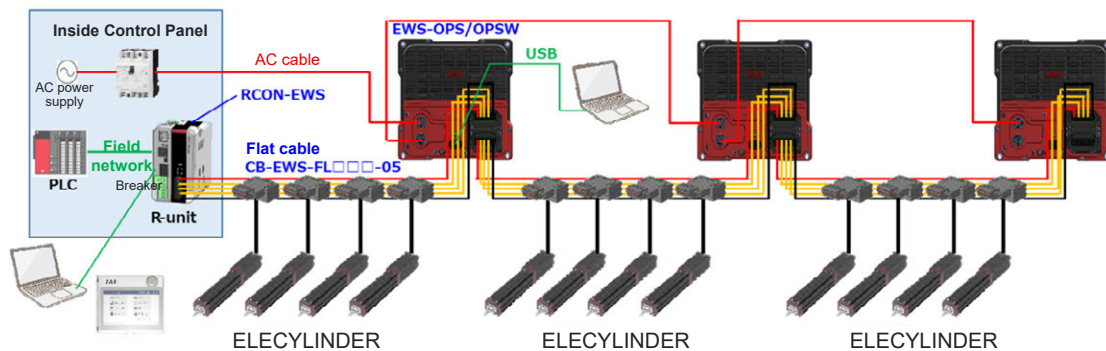

Fig. 1.3-6

- Robust Structure Applicable for On Site Installation

A robust frame utilizing die-cast enable installation outside a control panel.

As there is no limitation to the installation posture, open space can be effectively used by installing the equipment to any open space.

- Simple Address Setup Features

After wiring the entire system, the address of ELECYLINDER can be automatically set simply by reconnecting the hard switch and the ELECYLINDER.

It is not necessary to set up the address one by one by connecting to a PC.

- Simple Debugging Features

Communication with ELECYLINDER is available by connecting a PC to the USB on the power supply unit.

Position data and parameters can be set up by not opening a control panel and connecting to R-Unit.

* To go back from the debugging status to the normal status, it is necessary to reboot the power.

- Cable Length from Control Panel to ELECYLINDER Extended (30m Max)

By adding this product which is capable of parallel operation to a point where voltage has dropped, it can be used to boost voltage. As it can be installed to any open space of equipment, the capacity of a system can be easily increased.

(* The figure below is an image of the wiring.)

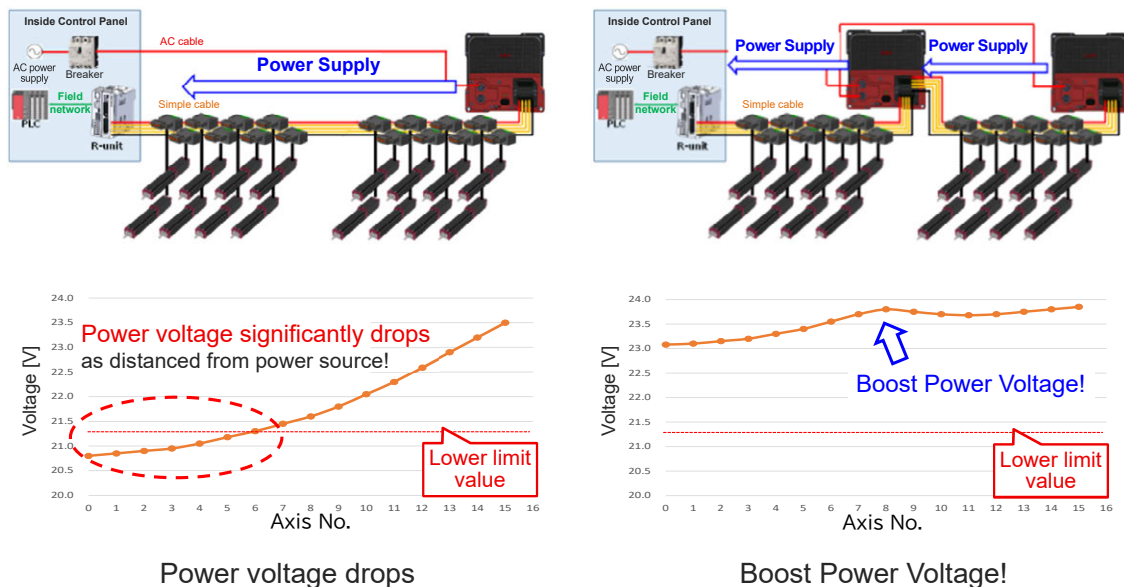

Fig. 1.3-7

4.1 System configuration

4.1.1 Standard specification

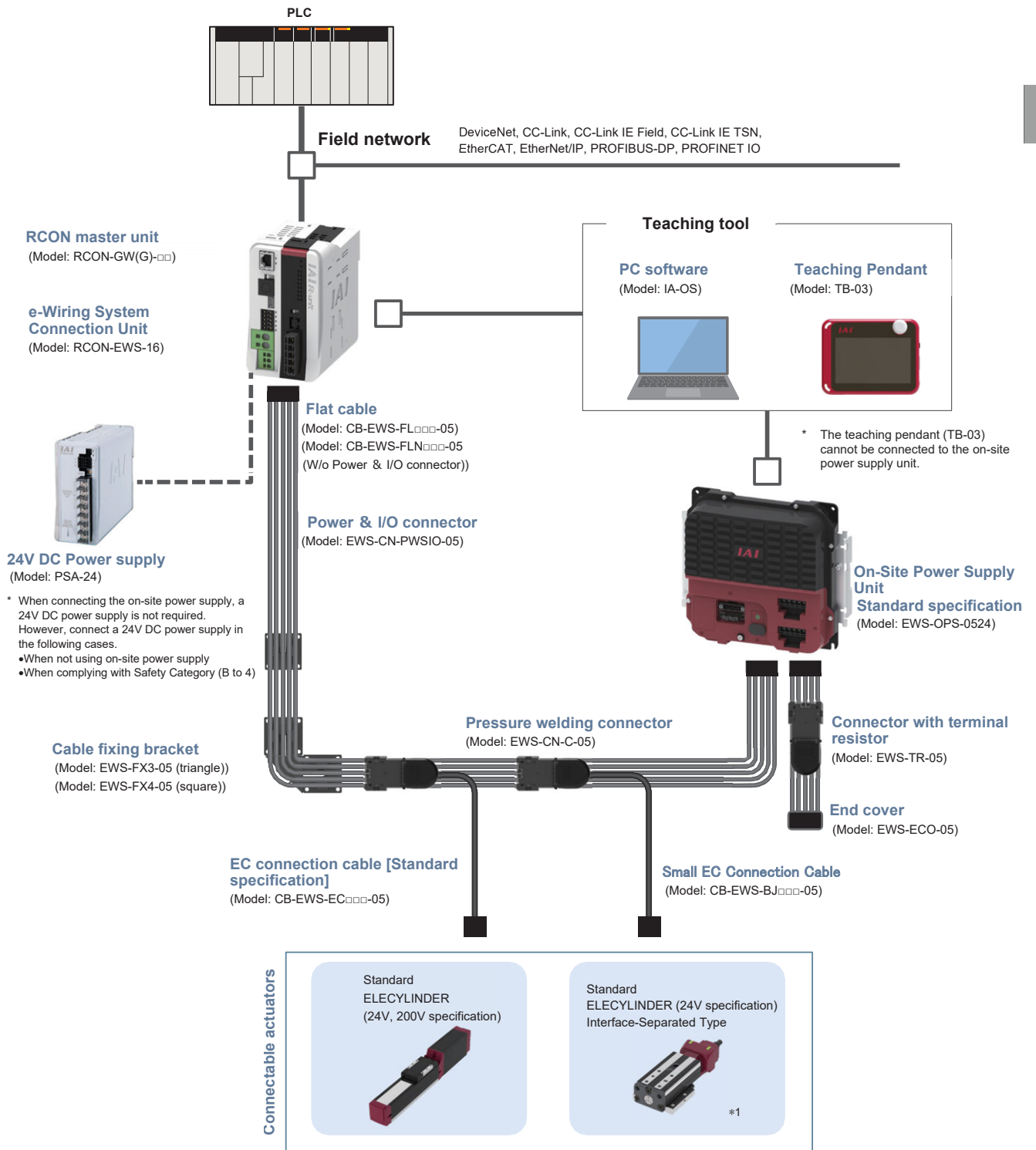

Fig.4.1-1 Standard Specifications System Configuration

4.1.2 Dust and Splash Proof Specification

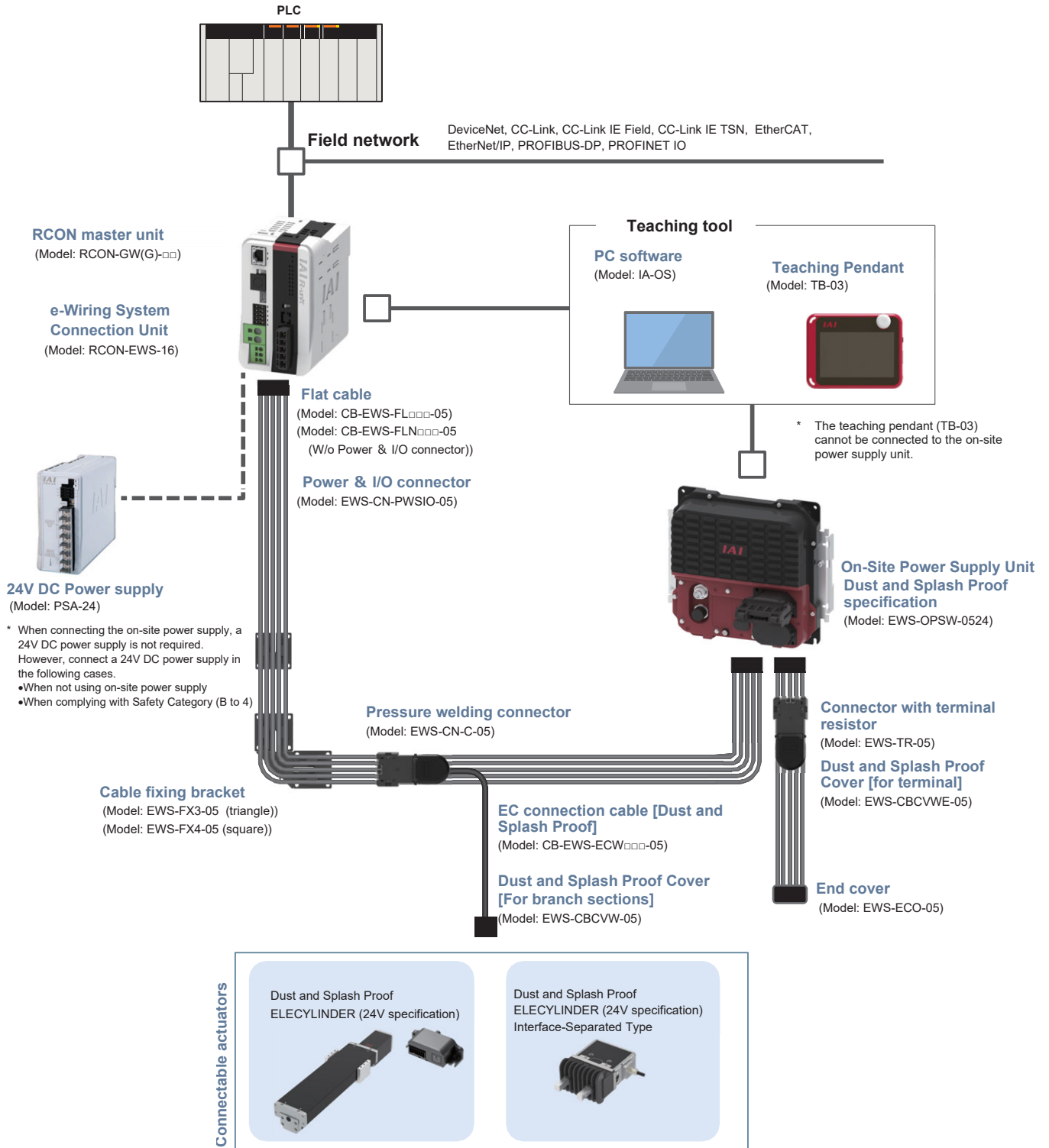

Fig. 4.1-2 Dust and Splash Proof Specification System Configuration

[Example for Wiring 2]

“After wiring to the actuator, connect it to the control panel” (adjust the cable length on the equipment side)

(1) First, connect the flat cable to the control panel and route it to the equipment.

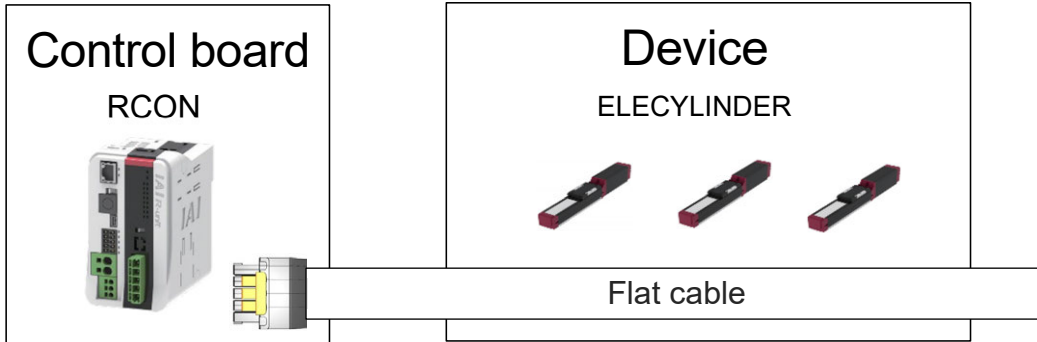

Fig. 4.2-3 Example for Wiring 2-1

* In this case, purchasing a flat cable equipped with a power supply connector (CB-EWS-FL□□□-05) is convenient, as it eliminates the need for the customer to attach the connector themselves.

(2) Wire it to the ELECYLINDER and cut off any excess flat cable.

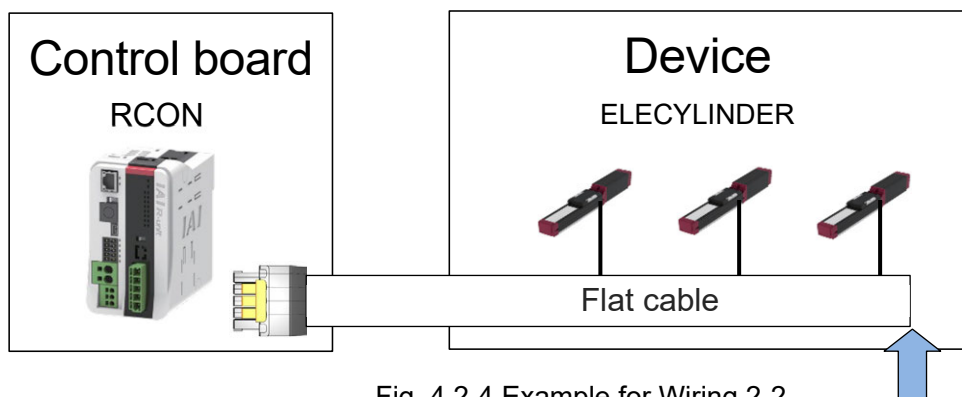

Fig. 4.2-4 Example for Wiring 2-2

Since the end can be cut to the optimal length, there is no wasted cable.

About Terminal processing

Perform the following two procedures on the end of the cable in the e-Wiring System:

- Connecting the termination resistor

Attach a connector with a termination resistor (Standard: EWS-TR-05, Dust and Splash Proof: EWS-CBCVWE-05).

- Processing the cut cable end

Apply insulation treatment to the cut cable end.

If necessary, purchase an end cover (EWS-ECO-05).

[Example of Wiring Using On-site Power Supply]

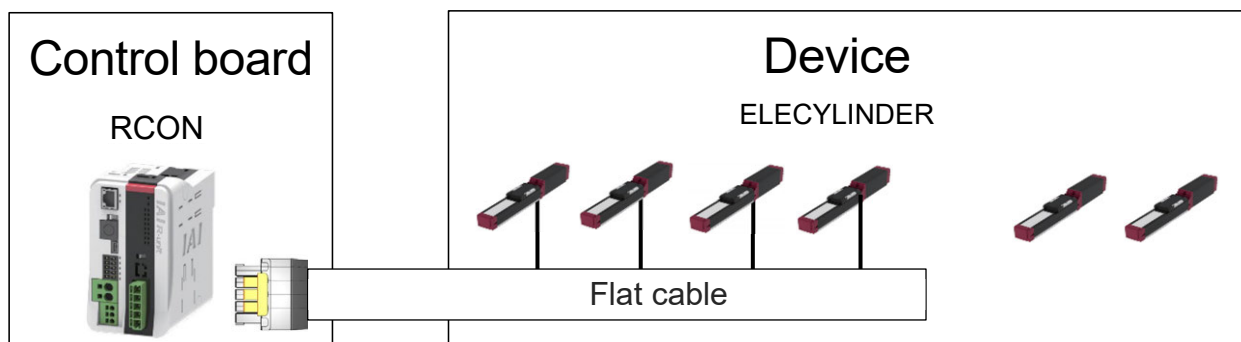

Fig. 4.2-5 Example for Wiring 3-1

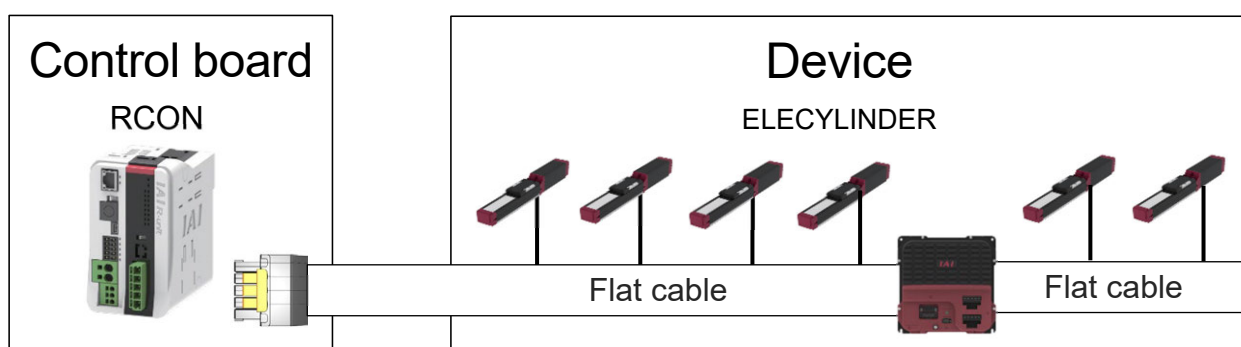

Fig. 4.2-6 Example for Wiring 3-2

The e-Wiring System allows multiple ELECYLINDER units to be connected with a single cable as shown in the diagram above.

If an alarm due to voltage drop occurs, adding an auxiliary on-site power supply (EWS-OPS/OPSW-0524) makes it possible to increase the number of connectable units and the wiring length.

- Wiring guideline ELECYLINDER: 4 units, Wiring length: 10m

(This is a reference for operation under conditions close to the rated specifications of the ELECYLINDER.)

* It will vary significantly depending on the actual ELECYLINDER models and the operating load.

Necessary tools

Parallel pliers (with maximum opening of 27mm or greater)

Recommended tools: Knipex pliers wrench 86 03 300



Caution

- Use parallel pliers with a maximum opening of 27mm or greater.
The thickness of the IDC connector before locking is approximately 26mm.



Instruction manual available!
Refer to the instruction manual for detailed
connection instructions.
intelligentactuator.com/e-wiring-manual

