

Significant reduction in labor hours
Easy cable system

IAI
Quality and Innovation

An industry first!

e-Wiring System

What is the e-Wiring System?

Run the bus cable and branch off the branch cables as needed to connect to the actuators.

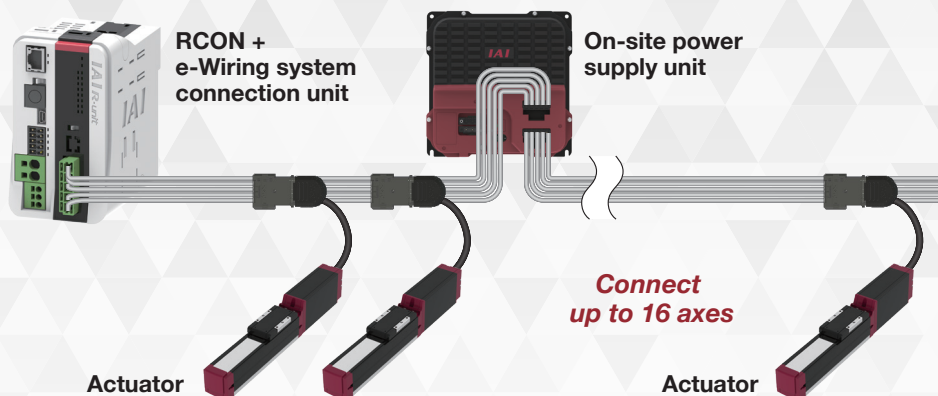

Application example

ELECYLINDER transfer unit with 12 axes

This unit clamps workpieces at the tip of the ELECYLINDER's cartesian axis

Conventional wiring

Space for the cable carriers installation is needed

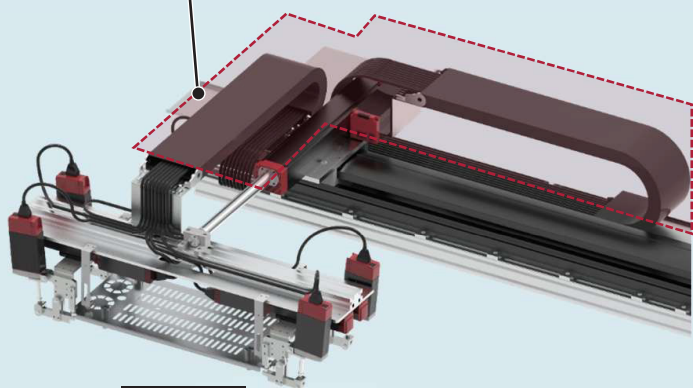

BEFORE

Power unit installation space is necessary inside the controller

The excess cables are coiled up

e-Wiring System

POINT

No cable carriers needed!

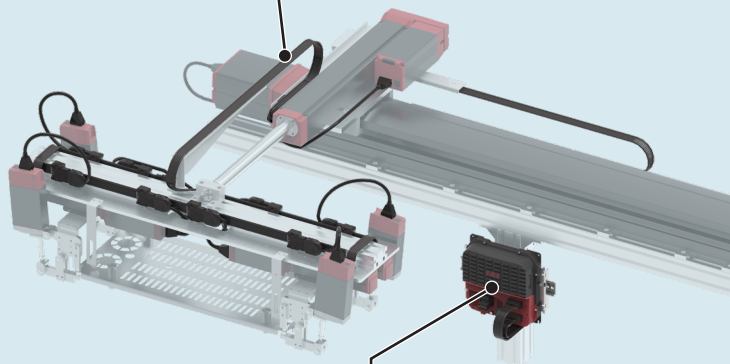

AFTER

Installing a 24V power supply within the work site helps save space in the control panel.
(Our PSA-24 can be installed in parallel with the on-site power supply unit)

No unnecessary cables!

Reduces labor hours at each stage from design to maintenance

Design

BEFORE

Requires selecting cable length for each actuator

AFTER

No need to select cable length



Reduces Design Time

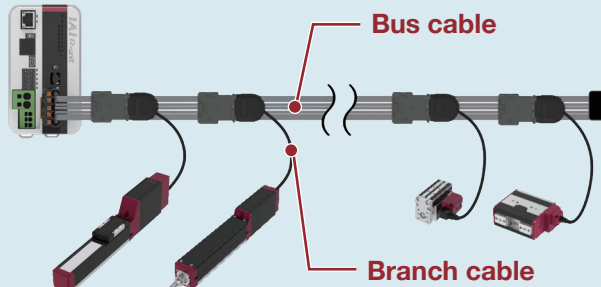

Run the bus cable on the equipment and branch off the branch cables using dedicated connectors.

Assembling

BEFORE

Wiring work takes time because there are many cables

AFTER

Cable installation labor hours



Approx.

64% Reduced

Labor time of conventional wiring work
(Our actual measurement result)

124 minutes

Wiring labor time for the e-Wiring System



45 minutes

Maintenance

BEFORE

Multiple types of cable lengths are necessary for maintenance of each actuator

AFTER

Maintenance cables are significantly reduced to just two types



In addition!

- ✓ No need to purchase excessively longer cables, **saving resources!**
- ✓ Only the exact amount of cables are purchased, **reducing costs!**
- ✓ **Lower cost** due to shorter total cable length!



Can be cut to the required lengths

Instruction manual available!

Refer to the instruction manual for detailed connection instructions.
intelligentactuator.com/e-wiring-manual



Manual



← The product catalog is coming soon!

IAI America, Inc.

USA Headquarters & Western Region (Los Angeles): 2690 W. 237th Street, Torrance, CA 90505 (310) 891-6015
Midwest Branch Office (Chicago): 110 East State Parkway, Schaumburg, IL 60173 (847) 908-1400
Southeast Branch Office (Atlanta): 1220 Kennestone Circle, Suite 108, Marietta, GA 30066 (678) 354-9470

www.intelligentactuator.com

IAI Group Headquarters and Main Factory:
1210 Iharacho, Shimizu-ku, Shizuoka-shi, Shizuoka, 424-0114, JAPAN

The information contained in this product brochure may change without prior notice due to product improvements.

IAI Industrieroboter GmbH

Ober der Röth 4,
D-65824 Schwalbach am Taunus, Germany

IAI Robot (Thailand) Co., Ltd.

825 Phairojkkijja Tower 7th Floor, Debaratana Rd.,
Bangna Nuea, Bangna, Bangkok 10260, Thailand

IAI (Shanghai) Co., Ltd.

SHANGHAI JIAHUA BUSINESS CENTER A8-303,
808 Hongqiao Rd. Shanghai 200030, China